

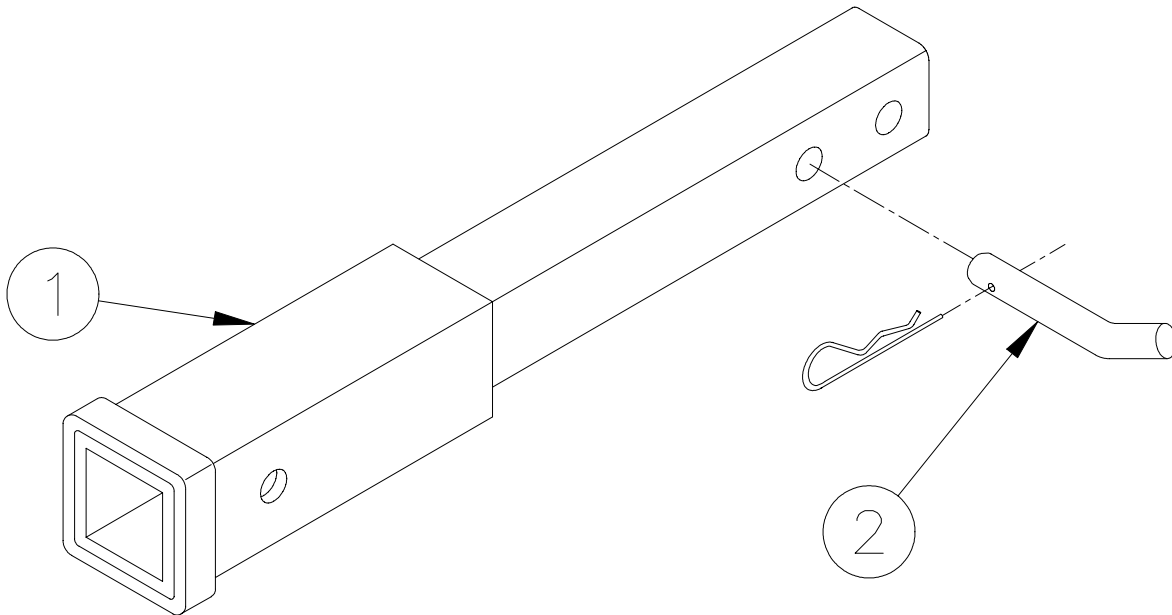

Installation Instructions
Receiver Extension, Class IV*
BX88160

1. Slide the receiver extension into the receiver hitch and pin it in place with the 5/8" pin and clip provided.
*Maximum weight distributing of 250 lbs at tongue, with 7500 lbs towing capacity.



Parts List

Ref. No.	Qty.	Part No.	Description
1	1	61-5551	Weldment, Receiver Extension, bx88160
2	1	200-1483	Pin, 5/8 X 3 Eff. w/ clip

Automatic