

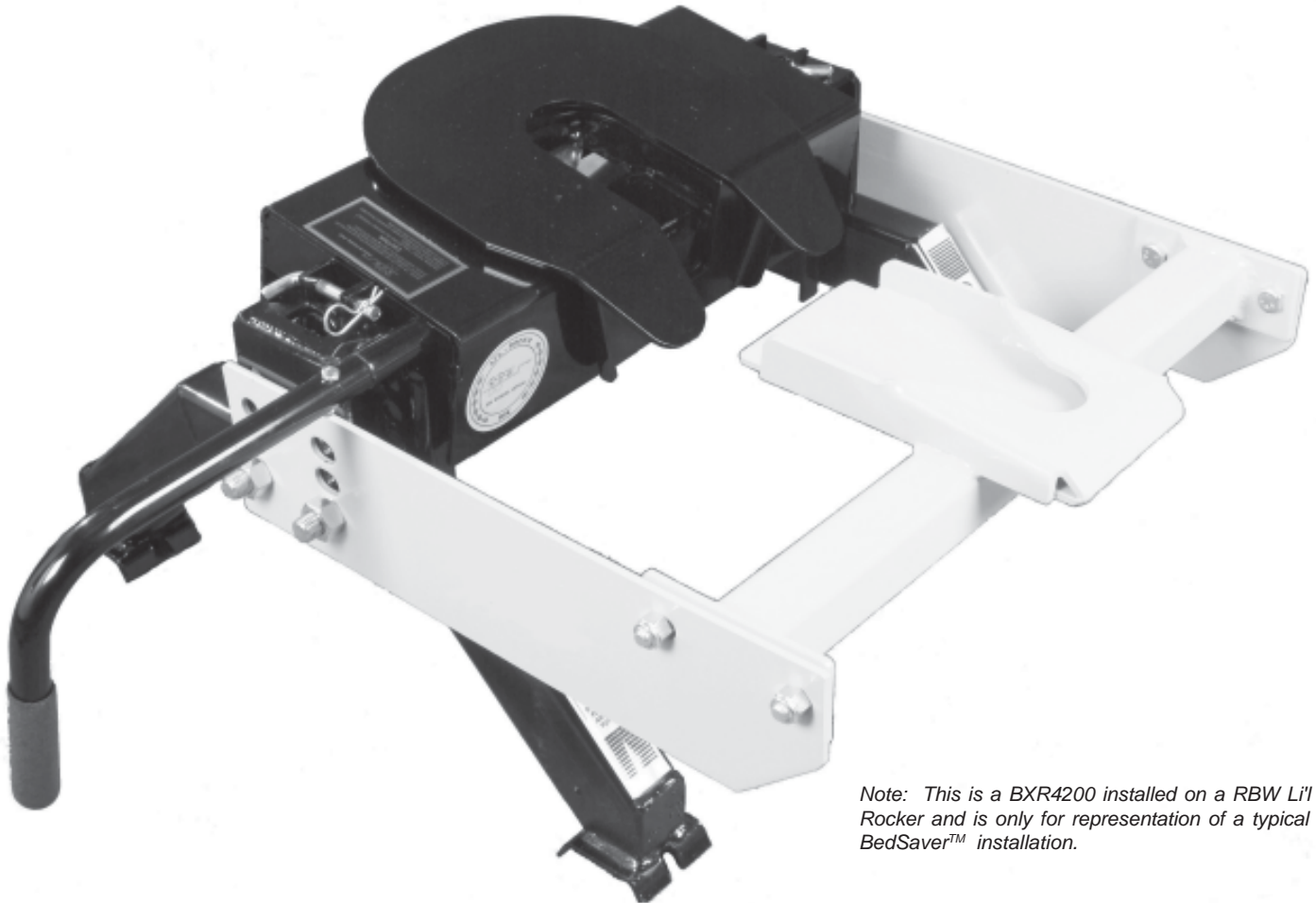

Strong As An Ox™

BedSaver™

Serial No.



Note: This is a BXR4200 installed on a RBW Li'l Rocker and is only for representation of a typical BedSaver™ installation.

Operator and Installation Manual BXR4600 Hijacker Hitch 16K Ultra

Unless otherwise specified, the bedsaver will NOT work with aftermarket pin boxes. See fit list.

TO BE VALID, THE WARRANTY CARD MUST BE COMPLETED IN ITS ENTIRETY BY AN AUTHORIZED DISTRIBUTOR OR DEALER AND SENT TO AUTOMATIC EQUIPMENT MFG. CO., PENDER, NEBRASKA OR REGISTERED ONLINE AT www.blueox.us. FAILURE TO DO SO WILL VOID THE WARRANTY.

© 2005 Blue Ox Division, Automatic Equipment Mfg. Co. • One Mill Road, Industrial Park Pender, Nebraska 68047 • Phone 402-385-3051 • Fax 402-385-3360 • www.blueox.us

Go RVing
Life's A Trip™



Strong As An Ox™

Safety Information

SPECIAL DANGER MESSAGE

The act of uncoupling your fifth wheel trailer from your tow vehicle is, singularly, the most dangerous act to be performed when RVing. Many accidents have occurred where broken bones, severed limbs and even death by crushing have resulted from inadvertently dropping the fifth wheel trailer when a person has placed part of his/her body between the tow vehicle and the frame of the fifth wheel trailer. All of these accidents are completely avoidable by following a few simple rules, even without installing BedSaver™ on your hitch.

- Chock/Secure your trailer wheels.
- Extend your front jacks until you see no weight is on the hitch.
- NEVER place any part of your body between the trailer frame and tow vehicle or hitch.
- NEVER allow any helper or observer to place any body part between the trailer frame and tow vehicle or hitch.

BedSaver™ prevents damage to your tow vehicle™ when an inadvertent release happens. BedSaver™ may NOT prevent injury to someone violating the simple rules above.

For a safe and happy RVing experience, follow the above rules and NEVER COMPROMISE them.

Safety Information

- 1) Blue Ox™ strongly recommends dealer installation and/or by a certified technician.
- 2) DO NOT ATTEMPT TO INSTALL THIS PRODUCT WITHOUT FIRST READING THESE INSTRUCTIONS.
- 3) WARNING! FAILURE TO INSTALL THIS PRODUCT PROPERLY CAN RESULT IN DAMAGE TO YOUR FIFTH WHEEL TRAILER, TOW VEHICLE, FIFTH WHEEL HITCH AND/OR CAUSE BODILY INJURY.
- 4) This product is not designed or intended for use with fifth wheel trailers having a pin weight of 4000 pounds or more.
- 5) Your BedSaver™ should be inspected for damage after each incident. Note: An incident is defined as any time BedSaver™ catches your trailer.

Special Messages

“NOTE” provides enhancement information pertinent to the specific step of the procedure being undertaken.

“CAUTION” indicates a potential hazard exists that could result in damage to the tow vehicle, fifth wheel trailer or the fifth wheel hitch.

“WARNING” indicates a potential hazard exists that could result in personal injury, or death

Assumptions

It is assumed that your Hijacker hitch is installed properly. If not, have your hitch installed by a certified technician.



Strong As An Ox™

Parts List

Inspect the parts in your kit and check them off against the pictures and parts list below.

| <u>Qty</u> | <u>Description</u> | <u>Picture #</u> |
|------------|--|------------------|
| 1 | Cross tube Weldment | 1 |
| 2 | Side plate | 2 |
| 2 | Spacer | 3 |
| 12 | Bolt, 1/2"-13 X 1 1/2", Zinc Plated | 4 |
| 12 | Lock Nut, Nylock, 1/2"-13, Zinc Plated | 5 |

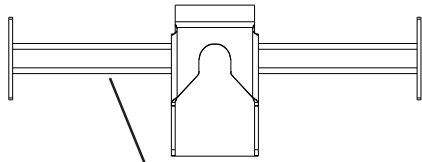

Picture 1

Location of Serial & Model #'s

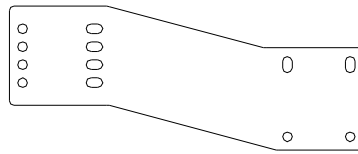

Picture 2

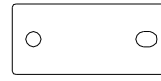

Picture 3



Picture 4



Picture 5

If any of these parts are missing refer to page 6 for part numbers then, call a Blue Ox™ dealer or the factory.
For Blue Ox 24/7 Customer Care can 1(888)425-5382

Tools Required

3/4" Socket

3/8" Drive Ratchet

3/4" Comb. Wrench

Torque Wrench

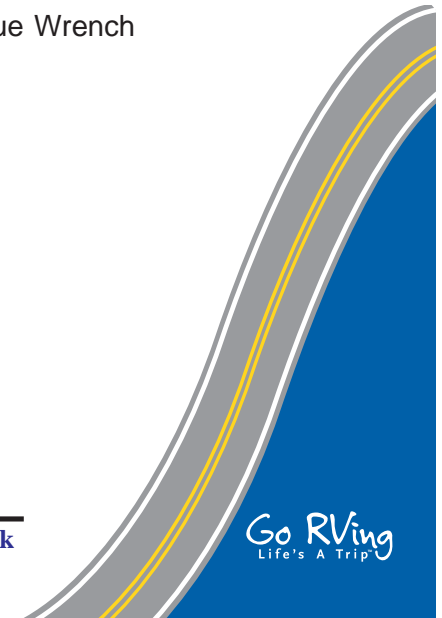

Go RVing
Life's A Trip™



Strong As An Ox™

Installation

Requirements for placement of BedSaver™ Side Plates

The BedSaver™ Side Plates are mounted with the bottom mounting holes aligned with the Hitch Side Frame bottom mounting holes. The BedSaver™ Side Plates are mounted with the beveled corners located on the bottom and toward the rear of the tow vehicle.

Note: You will find a label on each Side Plate. The labels should be placed to the outside of the hitch.

Step 1

To ease installation of the side plate, it is necessary to remove the hitch head. This allows access to the hardware that secures the vertical supports. At each end of the hitch, remove the hairpins that secure the clinch pins (which hold the hitch head on the hitch frame). Refer to **Figures 1** and **2** below for details.



Figure 1-Removing Hitch Head Clip



Figure 2-Removing Hitch Head Pin

Step 2

Carefully lift the hitch head off of the frame and set aside.

Step 3

To mount the BedSaver™ Side Plates, it is necessary to replace the vertical support mounting bolts with slightly longer mounting bolts and reversing their direction. You will be discarding the original bolts and nuts. Using a 3/4" socket and a 3/4" wrench, remove one vertical support mounting bolt. **NOTE: Each bolt will be replaced one at a time to ensure the vertical supports remain in their original positions.** Replace this bolt with one of the 1/2-13 x 1 1/2" bolts supplied in the kit. Place this bolt and existing washer in the hole just vacated from the inside of the hitch, with the threads to the outside of the hitch. Do not put a nut on the bolt at this time.

Step 4

Repeat Step 3 above for the remaining seven vertical support mounting bolts, four for each support. See **Figures 3** and **4** on page 3 for details. **NOTE: The shanks (threaded ends) of all four bolts should now be outside the hitch and ready to receive the BedSaver™ Side Plates.**



Strong As An Ox™

Installation Cont.



Figure 3-Right Side Plate installation

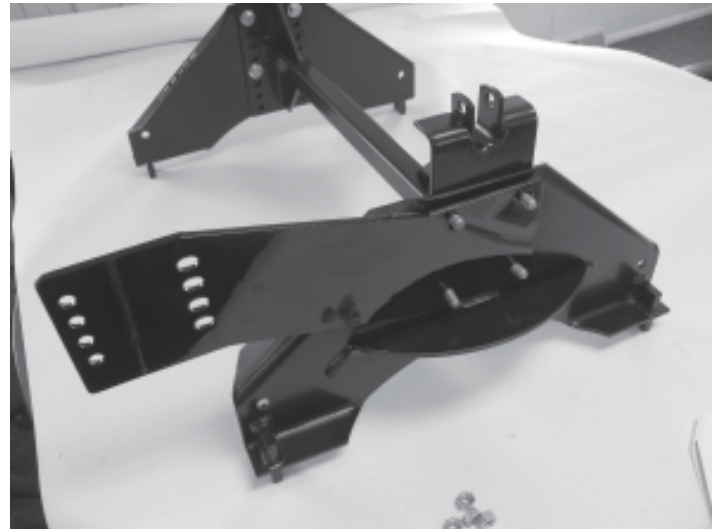

Figure 4-Right Side Plate attached

Step 5

Place the Side Plates and spacers onto the four protruding bolts on each side, installed in **Steps 3 & 4**.

Step 6

Install the four mounting nuts on the mounting bolts securing the Left Side Plate. Finger tighten only.

Step 7

Install the four mounting nuts on the mounting bolts securing the Right Side Plate. Finger tighten only.

Step 8

Refer to **Figure 5**, page 5. Examine the hitch, particularly the positioning of mounting bolts securing the Hitch Side Frames (these mount the Hitch Head Cradle to the side supports). There are eight pairs of mounting holes. Counting from the bottom pair of mounting holes (bottom = 1, top = 8, See Figure 5, page 5), take note of the pair of mounting holes in which the bolts are installed. If the bolts are located in position 4 & 8, then the cross tube weldment should be installed in bottom most position, (Position 1, see Picture 6 below). The Cross tube should be moved vertically on the Side Plates one hole for every position the hitch head Cradle is moved from positions 4 & 8. For example: Hitch Head positions 3 & 7, then the BedSaver should be in position 2.

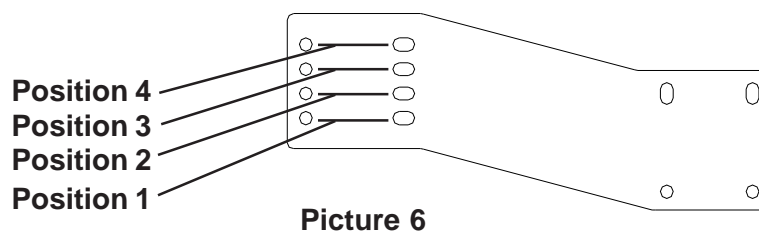

Picture 6



Strong As An Ox™

Cross Tube Installation

Step 9

Temporarily lift and place the hitch head back onto the vertical supports. **NOTE: Do not insert the clinch pins and hairpins.** Tilt the hitch tabletop down as far as it will go. Inspect the position of the Catcher with respect to its proximity to the bottom-most edge of the ramp. The Catcher should be approximately 1-2" aft and slightly below the hitch king pin opening. If so, the Side Plates are installed in the correct position. If the Catcher is too high and is positioned above the bottom-most edge of the ramp, it will be necessary to lower the Side Plates one position (to the top hole pairs). However, it is likely the center pair of holes in the Side Plates will suffice. When you determine the Catcher is properly positioned, remove the hitch head again and place nearby. Tighten nuts on the the Vertical Support mounting bolts to a minimum of 65 ft-lbs. **NOTE: When tightening the Side Plates to the hitch frame sides, it may be necessary to lift the Side Plate for proper alignment and leveling.**

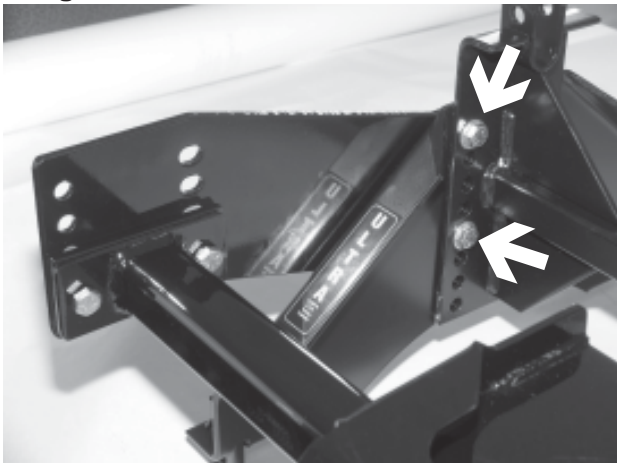

Figure 5-Cross tube & spacer attachment

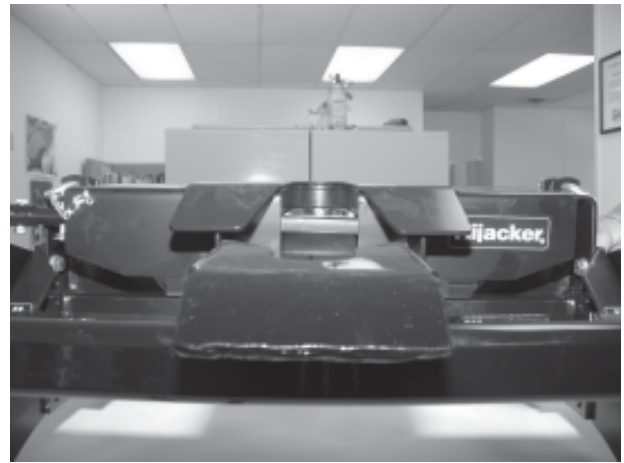

Figure 6-Complete installation, rear view

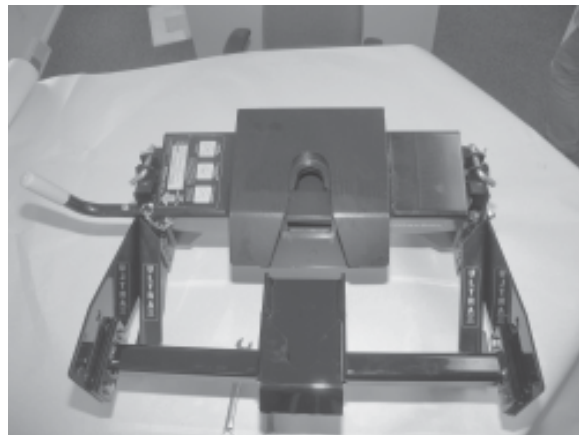

Figure 7-Complete installation, top view

Step 10

Reinstall Hitch Head then inspect your work and check to be certain all nuts and bolts have been properly tightened. A sample installation is shown in **Figures 6 and 7.**



Strong As An Ox™

Parts List

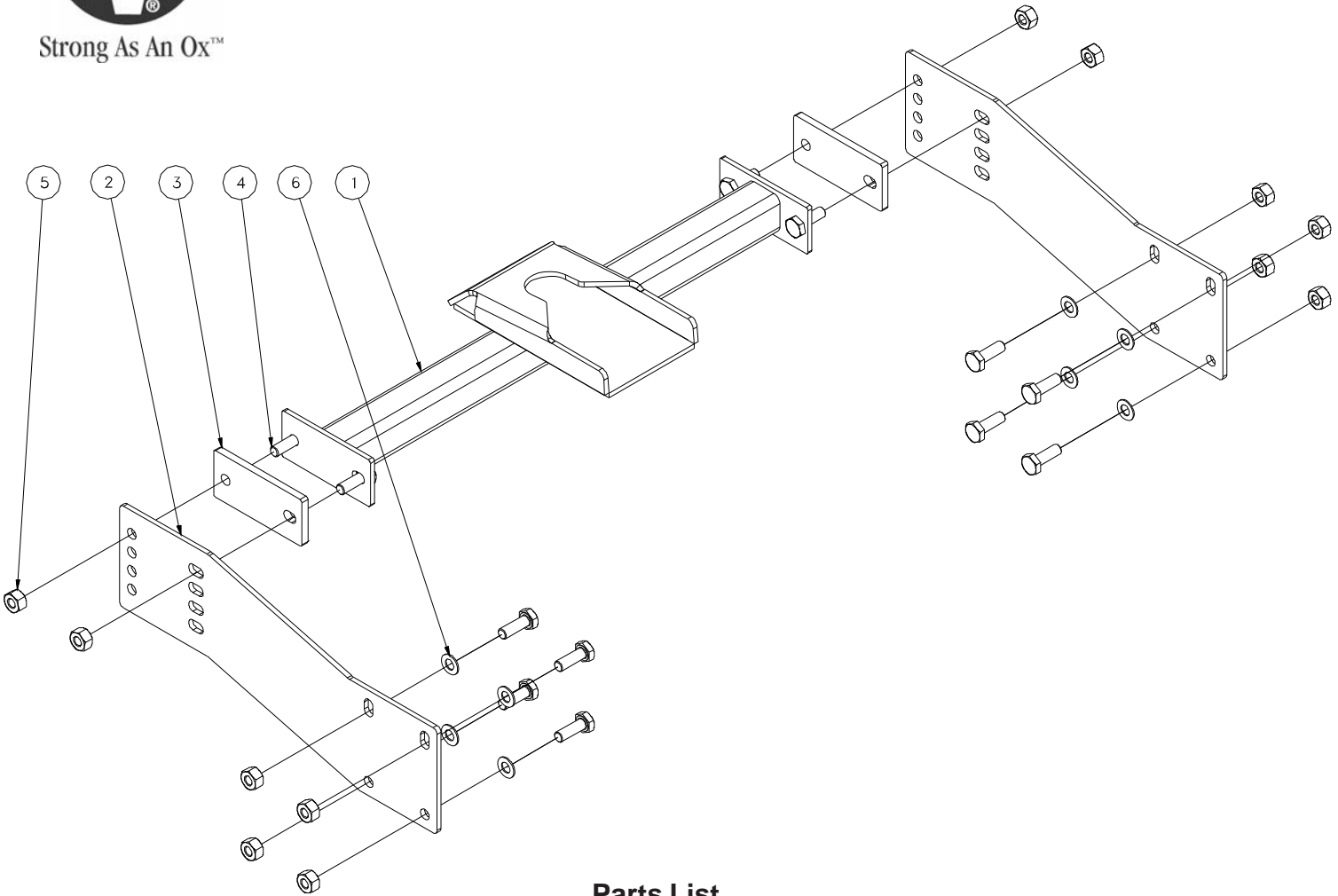

Parts List

| Ref. No. | Qty. | Part No. | Description |
|----------|------|----------------|------------------------------------|
| 1 | 1 | 61-6113 | WLDM'T, BEDSAVER X-TUBE, 27 1/2 |
| 2 | 2 | 101-6798 | PLATE, BEDSAVER SIDEPLATE, BXR4600 |
| 3 | 2 | 102-6620 | FLAT, SPACER, BEDSAVER |
| 4 | 12 | 201-0568 | 1/2-13 X 1 1/2 HEX BOLT, GRD. 8 |
| 5 | 12 | 202-0094 | 1/2-13 HEX NYL. INS. LOCK NUT, ZP |
| 6 | 8 | Existing Parts | 1/2 FLAT WASHERS |

IMPORTANT: Use only genuine factory replacement parts on your bracket kit. Do not substitute homemade or non-typical parts. If a bolt is lost or in need of replacement, for your safety and the preservation of your bracket kit, be sure to use a replacement bolt of the same grade. Repair parts may be ordered through your nearest **Blue Ox™** dealer or distributor.