



TigerTrak

TT2301 Instructions

Chevrolet P-30
Motor Home Chassis Rear Bar



Torque Specs

Bolt Description	Torque Spec.
1/2 x 4.5 U-bolt	75 ft/lbs
1/2 x 1 1/2 USS GR. 8	95 ft/lbs
1/2 x 2 USS GR. 8	95 ft/lbs
1/2 x 2 1/2 USS GR. 8	95 ft/lbs
1/2 x 3 USS GR. 8	95 ft/lbs
1/2-13 x 1 SQ. Set Screw	75 ft/lbs
1/2 x 1 1/4 SAE GR. 8	75 ft/lbs
5/8 x 2 SAE GR. 8	150 ft/lbs
5/8 x 2 3/4 SAE GR. 8	150 ft/lbs
3/4 x 3 SAE GR. 5	150 ft/lbs
3/4 x 3 1/2 SAE GR. 5	150 ft/lbs
3/4 X 5 SAE GR. 5	150 ft/lbs
12-1.75 x 55 MM HEX 10.9	65 ft/lbs
12-1.75 x 120 MM HEX 10.9	65 ft/lbs
12-1.75 MM HEX NUT 10.9	65 ft/lbs
14-2.0 x 40 MM HEX 10.9	125 ft/lbs
14-2.0 x 80 MM HEX 10.9	125 ft/lbs

! ATTENTION

Use these torque specs, **UNLESS** otherwise specified.

Tools Required

1-1/8" Combo Wrench	1-1/8" Socket
3/4" Combo Wrench	3/4" Socket
1/2" Drive Ratchet	15/16" Socket
1/2" x 6" Extension	Torque Wrench

! ATTENTION

A qualified mechanic using normal automotive tools and following all safety measures known should perform installation of this product.

TigerTrak

TT2301 Instructions

Chevrolet P-30 Motor Home Chassis Rear Bar

Parts List

Ref. No.	Qty.	Part #	Description
1	1	101-7116	BRACKET, AXLE, TT2301
2	1	107-2968	TUBE, THRD ROD, TT2300
3	1	61-6425	WLDM'T, FRAME BRKT, TT2300
4	1	229-0734	FRAME BRKT, NUT PLATE, TT2300
5	1	61-6430	WLDM'T, ROD END, LH THRD, TT
6	1	61-6418	WLDM'T, ROD END, RIGHT THREAD, TT
7	2	201-0632	3/4-16 X 3 HEX BOLT GR 5 ZP
8	4	203-0007	3/4 FLAT WASHER, ZP
9	4	250-0217	BUSHING, URETHANE, TT
10	2	107-2969	TUBE, BUSHING INSERT, TT
11	2	202-0168	3/4-16 STOVER LOCK NUT ZP
12	1	202-0149	3/4-16 NUT, HEX JAM, ZP
13	1	202-0186	3/4-16 LH, JAM HEX NUT, ZP
14	2	201-0810	5/8-18 X 2 HEX BOLT, GRD.8, ZP
15	2	203-0167	5/8" LOCK WASHER, GRD 8, ZP
16	6	203-0106	5/8 SAE FLAT WASHER, ZP
17	2	201-0811	1/2-20 X 1 1/4" HEX BOLT, GRD.8, ZP
18	2	202-0184	1/2-20 JAM HEX NUT, GRD. 5, ZP
19	1	62-3625	ROD, ASSY, TT2300
20	4	202-0134	5/8-18 HEX LOCK NUT, TOP INSERT
	2	290-0275	8" LONG CABLE TIE, BLK (NOT SHOWN)
	1	XA1-0049	LOCTITE RED, 262, TUBE, .02 FL. OZ. (NOT SHOWN)

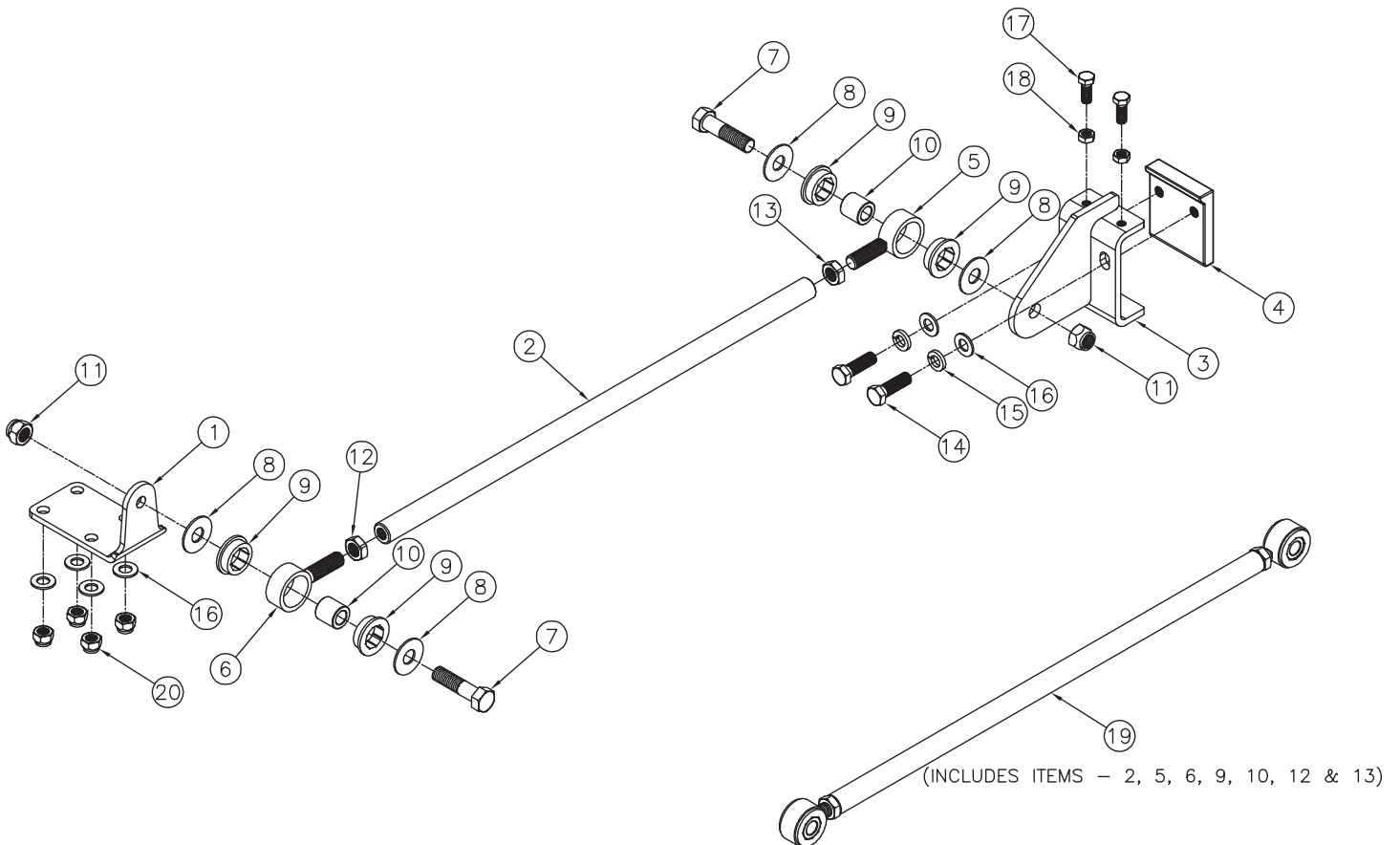

TigerTrak

TT2301 Instructions

Chevrolet P-30 Motor Home Chassis Rear Bar

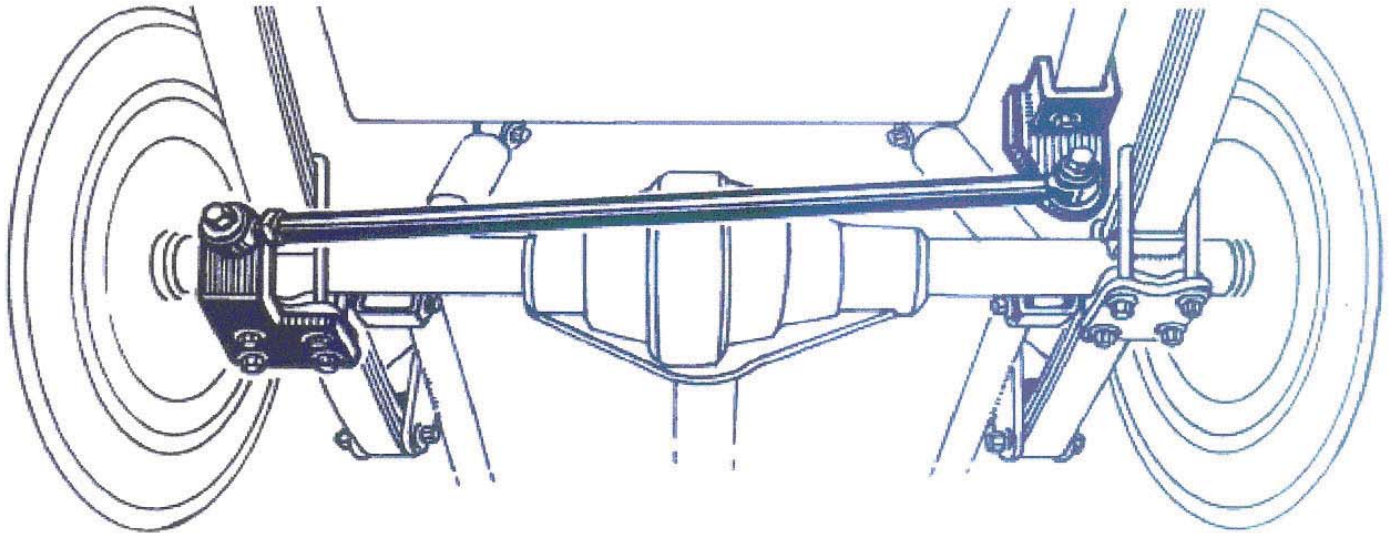

Installation Instructions:

1. Move the coach to a level, flat surface. By driving the coach back and forth 10 feet once or twice, ensure the vehicle's front wheels are straight ahead before starting installation. Set the brake and chock the wheels.

2. Install Axle Bracket (#1) on either side. Choose the side which has the most thread below the nuts on the U-bolts. (Clean threads with wire brush and lube threads.) Install Axle Bracket with supplied 5/8" lock nuts and tighten. Be sure to use Loctite on the bolts.

3. Place the Frame Bracket (#3) on the outside of the opposite side frame rail, and loosely secure it with the Nut Plate (#4) with the supplied 5/8" x 2" bolts. The Frame Bracket and Nut Plate must be able to move front to back on the frame. Install the two 1/2" x 1-1/4" bolts with jam nuts finger tight for now.

4. Now, align Frame Bracket (#3) front to rear, so when Rod Assembly (#19) is installed the Frame Bracket (#3) lines up with the Axle Bracket (#1). Now, alternately tighten the 5/8" and 1/2" bolts on the Frame Bracket (#3) and torque to spec. (See Chart). Tighten jam nuts.

5. With the coach at normal ride height, install the Rod Assembly (#19) to the Axle Bracket (#1). Use one of the supplied 3/4" x 3" bolts, two washers and nut, and then assemble loosely. Be sure that there is a flat washer on each side of the urethane bushings. Adjust the length of the rod until you are able to bolt on the supplied 3/4" x 3" bolt, two washers and nut.

6. Tighten the 3/4" bolt and nut on Axle Bracket (#1) to specifications (See torque chart). Tighten 3/4" bolt and nut on the Frame Bracket (#3) to specifications. Lastly, tighten the jam nut on the Rod Assembly (#19). See torque chart for all tightening specs. Inspect for any wires or hoses that may rub, if so use supplied split loom to cover the wires or hoses and the supplied snap ties to secure.



© 2007 Blue Ox
One Mill Road, Industrial Park
Pender, Nebraska 68047
Phone: (402) 385-3051 • Fax: (402) 385-3360
www.blueox.us