



## SC2000 Installation Instructions Motorcycle Carrier I

Serial No.

Congratulations in buying the SC2000 Motorcycle Rack from Blue Ox! Another quality product that Blue Ox has put on the market, that will give you many years of use.

**Note 1:** Make sure the motorcycle's weight does **NOT** exceed the rated tongue weight of the coach's hitch.

**Note 2:** There is a need to fabricate, additional spacers or tubes welded to the frame of the coach for the 6" receiver tubes to be mounted at the appropriate location. **Make sure outside extensions are supported enough to support the motorcycle.**

**Note 3:** When flat towing, Blue Ox strongly recommends using a brake system on the towed vehicle.

### Installation

1. Pin the receiver extension into the receiver of the coach, then bolt the deck to it with a 3/8-16 x 1 carriage bolt and nylon lock nut as shown in Figure A.
2. The outside receiver tubes will then need to be welded to the frame of the coach. The motorcycle deck that is bolted to the receiver extension will give you an idea where the 6" receiver tubes will need to go. The 6" receiver tubes will need to be located approximately 31" from the center of the coach's receiver to the center of the 6" receiver tubes as shown in Figure B. Once the outside extensions and 6" receivers are marked and held in place. Additional tubes may have to be welded to the C-Channels of the coach so the 6"

receiver tubes are located in the appropriate spot. (Fig.B) You may need to support the receiver extensions to hold them in place. Once they are both tacked, check to see if the top of the extension tubes are of all equal height. If not, the 6" receiver tubes will need to be repositioned. Also check to see if the tubes are parallel to the center extension. Once the outside receiver extensions are checked for equal measurements the two receivers can be welded completely. **Note:** Make sure the six inch

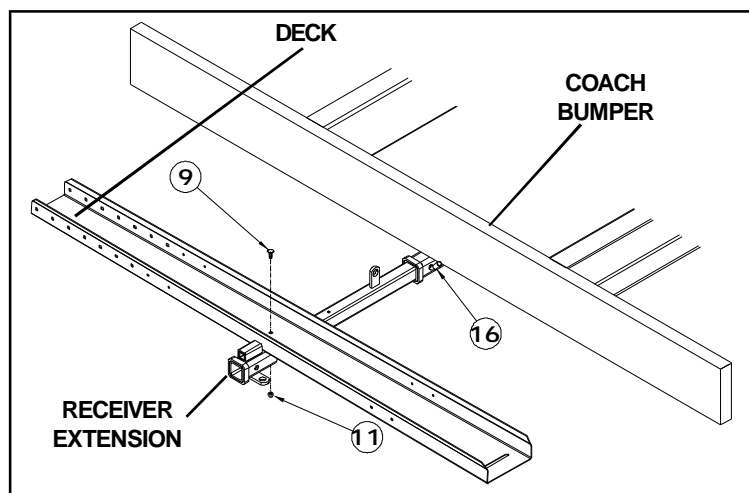

Figure A

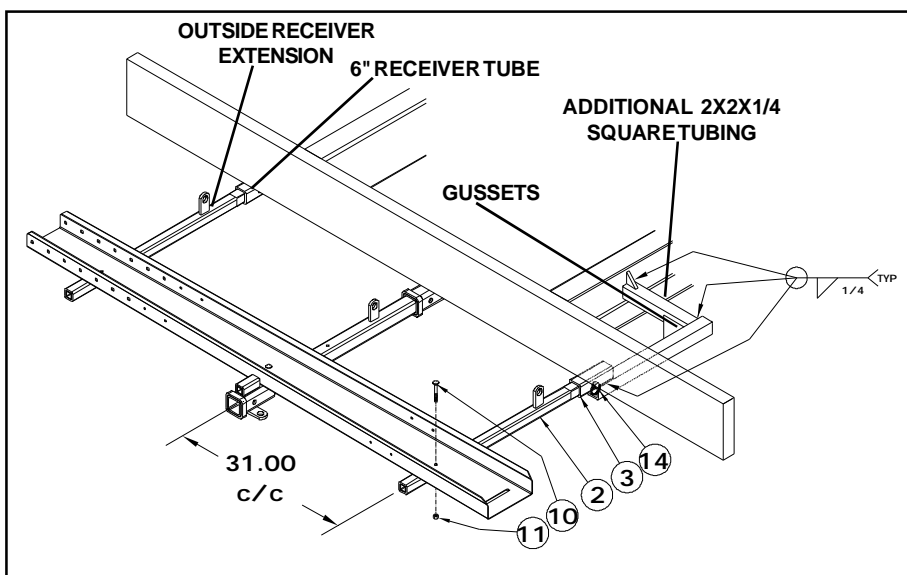
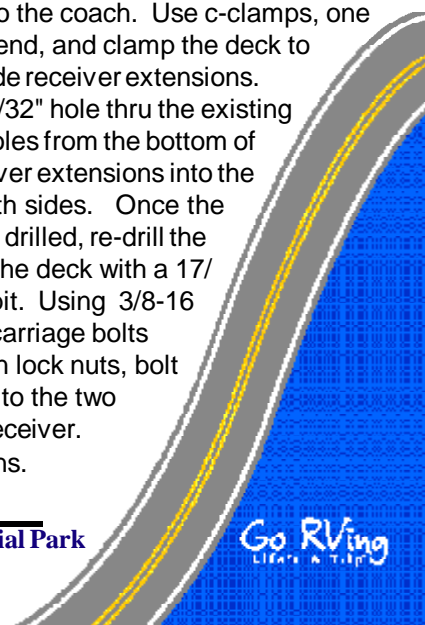

Figure B

receiver tubes are welded by a qualified welder!

3. Making sure the motorcycle deck is parallel to the coach. Use c-clamps, one on each end, and clamp the deck to the outside receiver extensions. Drill a 13/32" hole thru the existing 13/32" holes from the bottom of the receiver extensions into the deck, both sides. Once the holes are drilled, re-drill the holes in the deck with a 17/32" drill bit. Using 3/8-16 x 2 1/4" carriage bolts and nylon lock nuts, bolt the deck to the two outside receiver extensions.



Go RVing  
LIFE IS A TRIP



Strong As An Ox™

- Determine the approximate position of front tire support on the deck in order to have motorcycle centered over main receiver extension. Using the 3/8-16 x 1" carriage bolts and nylon lock nuts, attach front tire support to deck as shown in Figure C. Notice the way the head of the carriage bolts are placed on the inside of the track of the deck.

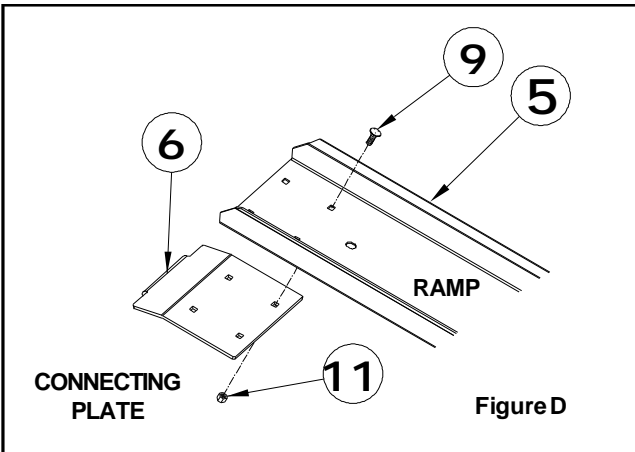

- Mount the connecting plate to the ramp with 3/8-16 x 3/4" carriage bolts and nylon lock nuts. Make sure the connecting plate is angled down, with the tab facing down. Look at Figure D. Attach the

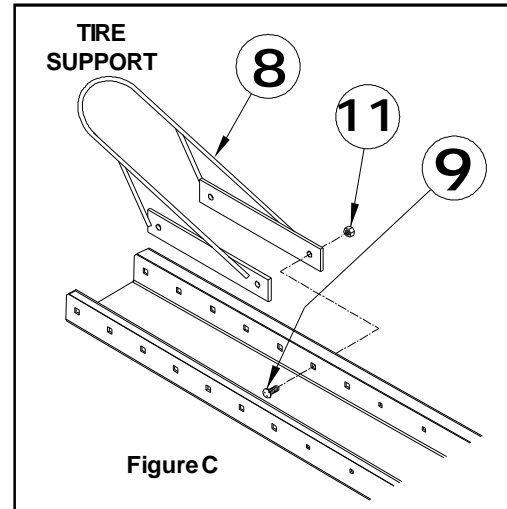
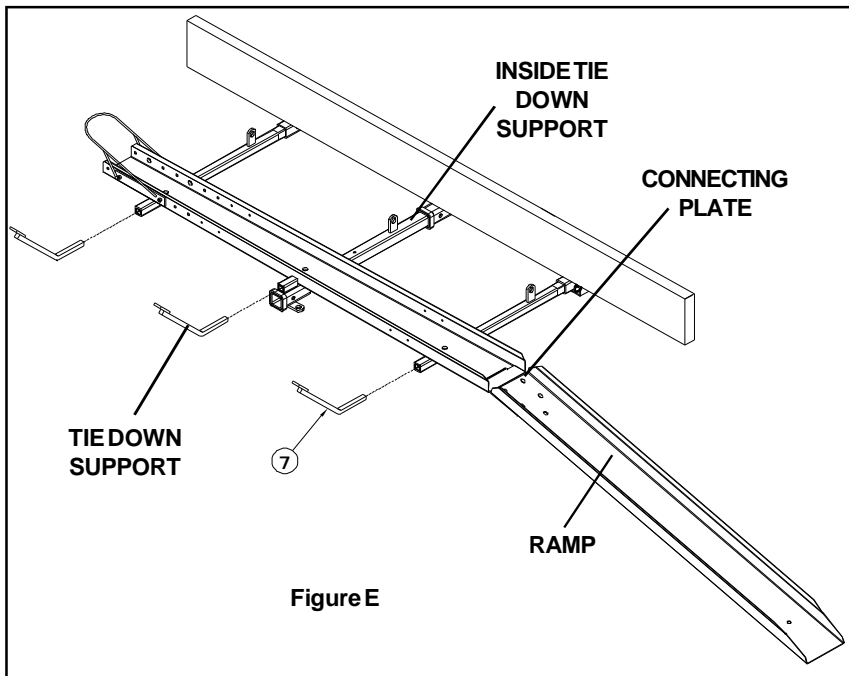

assembled ramp to the deck by placing the tab into the slot on the end of deck and insert the two quick pins into the of the ramp tab to help support the ramp. Insert the tie down supports into each of the receiver extensions as shown in figure E.

- The motorcycle can now be loaded up onto the motorcycle deck. Adjust front tire support, if needed, to insure that motorcycle is centered above main receiver extension.
- The motorcycle can be strapped down to the cycle deck using the three tie down supports on the front of the deck and the convenience links on the back of the receiver extensions. The tie downs will be supporting the motorcycle, so making sure that the straps (not included) are a good quality tie down straps and they are installed properly. This is very critical and will insure safe towing.

8. The ramp can be mounted behind deck on the main receiver extension with a 5/16-18 x 2 1/2" wing bolt and washer. Insert the wing bolt and washer in the pre-drilled hole on the ramp and through the existing hole on the top of main receiver extension and into the weld nut on the bottom extension, tighten firmly.

**SAFETY NOTE:** Be sure all bolts are tight before loading motor cycle. Make sure motorcycle is properly strapped down to the motorcycle tie downs and deck. Be sure to use all of the tie down supports supplied. When motorcycle is not loaded, be sure that tie down supports are removed. Tie down could fall out when driving motorhome.



Strong As An Ox™

## Tools Required

Ratchet  
9/16" Socket

Drill  
3/4" Wrench

13/32" Drill Bit  
9/16" Wrench

## Parts List

Ref. No.	Qty.	Part No.	Description	Ref. No.	Qty.	Part No.	Description
1	1	61-5632	Wdm't, Receiver Ext., Cycle Rack	9	9	201-0034	3/8-16x1" Carr. Bolt, Grd.5, ZP
2	2	61-5635	Wdm't, Receiver Ext., Outside	10	2	201-0172	3/8-16x2 1/4" Carr. Bolt, ZP
3	2	107-2397	Tube, Receiver, Cycle Rack	11	7	202-0090	3/8-16 Hex, Nylon Insert Lock Nut, ZP
4	1	101-6753	Motorcycle Deck, SC2000	12	4	202-0144	3/8-16 Hex, Nylon Jam Lock Nut, ZP
5	1	101-6751	Motorcycle Ramp, SC2001	13	1	201-0783	5/16-18 x 3 Wing Bolt, ZP
6	1	101-6752	Connection Plate, SC2001	14	1	203-0002	5/16 Flat Washer, ZP
7	3	61-6067	Weldment, Tie Down	15	2	229-0520	Pin, 1/2 x 2 5/8
8	1	299-0376	Wdm't, Tire Support, ZP	16	1	200-1483	Pin, 5/8 x 2 5/8 w/clip
				17	2	84-0001	Quick Pin Assembly

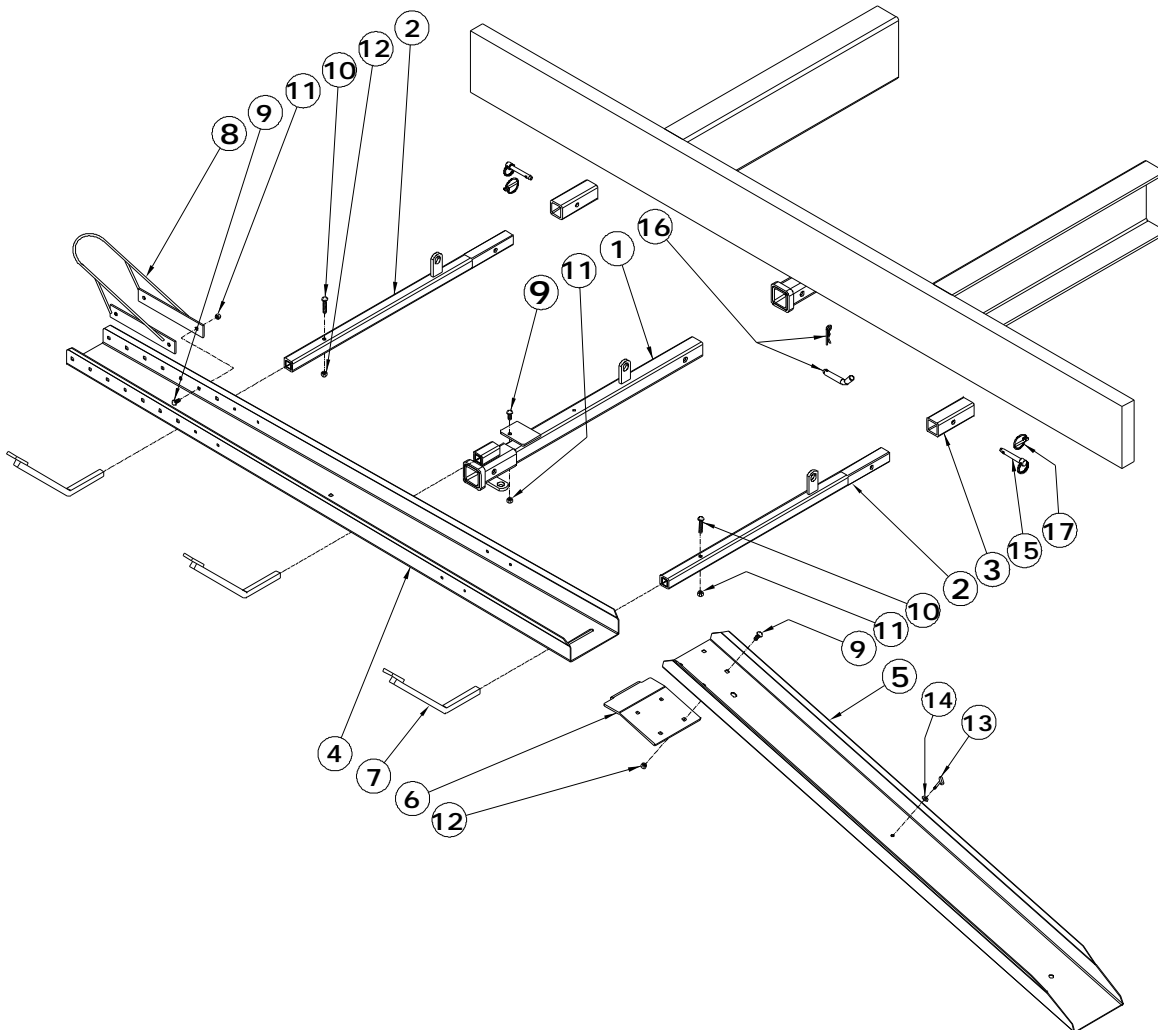

**IMPORTANT:** Use only genuine factory replacement parts on your Motorcycle Rack. Do not substitute homemade or nontypical parts. If a bolt is lost or in need of replacement, for your safety and the preservation of your motorcycle rack, be sure to use a replacement bolt of the same grade (Usually Grade 5, refer to parts list). Repair parts may be ordered through your nearest **Blue Ox** dealer or distributor.

© 2001, 06, 09 Blue Ox Division, Automatic Equipment Mfg. Co. • One Mill Road, Industrial Park  
Pender, Nebraska 68047 • Phone 402-385-3051 • Fax 402-385-3360 • [www.blueox.us](http://www.blueox.us)

Page 3 of 3      292-2661      1/19/09

Go RVing  
LIGHTS & TIPS